

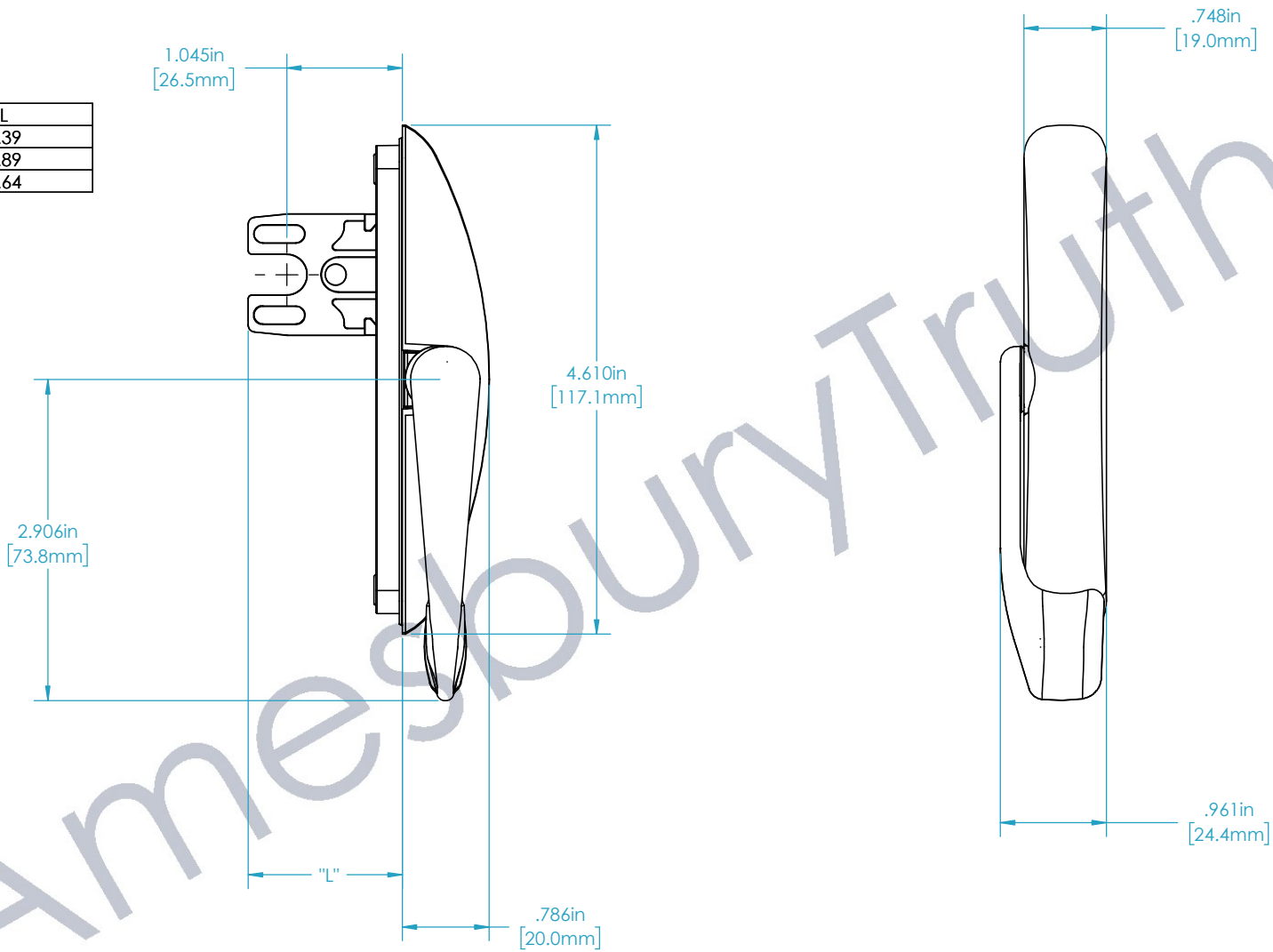

PART NO.	L
24.30	1.39
24.31	1.89
24.33	1.64



NOTES:

- (QTY 2) PN 19298 #10-24 PAN HEAD
- THREAD FORMING MACHINE SCREW

MATERIAL:		 Amesbury Truth Engineered Solutions. Trusted Results.	INTERPRET PER: ASME Y14.5M-2009	DRAWING TITLE:	
FINISH:			UNITS: INCH	DRAWN:	
HEAT TREAT:		THIRD ANGLE PROJECTION	SCALE: 1:1		SHEET 1 OF 1
SURFACE AREA: IN ²			CAD TYPE: SOLIDWORKS	SIZE: B	DRAWING #:
WEIGHT: LBS		<p style="text-align: right; color: red; font-weight: bold;">CUSTOMER PAGE</p>			